

CLOUD CLIMBERS
of S. E. LOUISIANA

Hot Air

Edited by:

Carl J. Bakay

118 Gentry Circle

Lafayette, LA 70508-6326

Day Tel.: 800-676-7302

Nite Tel.: 337-504-4363

carl.bakay@scientificdrilling.com

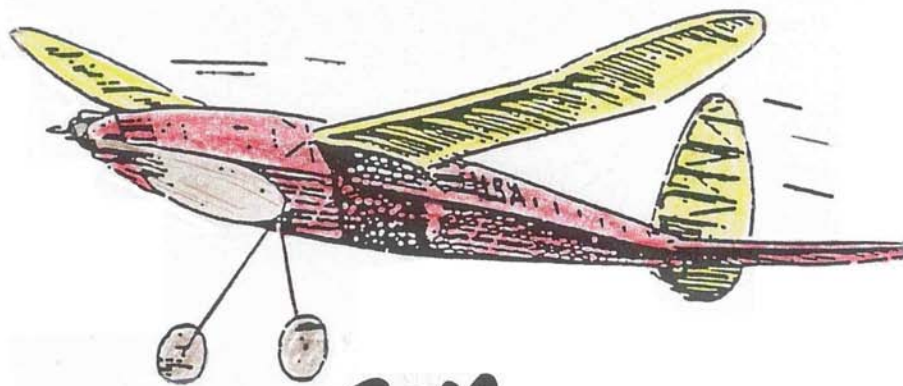

**SAM
CHAPTER
59**

www.sam59.org

January – February 2007

SOME HOT AIR

The December 9, 2006 meeting of the Cloudclimbers was a Saturday Christmas Party held at the home of Scott and Dona Cannon. A total of 10 members attended, most with their wives. We first exchanged presents, while in the Family Room, the ladies had their own tree ornament exchange. Jules Damare brought 8 or 10 extra rubber kits, and so we had a second raffle after the exchange.

The meeting was called to order with Carl Bakay as facilitator. Sharon Bakay gave a treasurer's Report that we had \$865 in the club checking account, and nothing owed. As Old Business, Carl reported that the Gulf States Annual brought in \$294 from 13 entries and the raffle, and cost a total of \$398 to put on, for a net cost to the club of \$104. This loss was entirely due to the decision to donate the \$99.00 proceeds of the raffle to the Navy Relief Fund, as a gesture of appreciation for using their field

Also as Old Business, Vince Burton brought up the question if we were going to do anything to thank the owner of Simpson's Sod Farm for use of the field. A meat and cheese basket was decided on, and Vince agreed to make the purchase.

The first order of New Business was to collect \$20.00 from all ten members present for 2007 dues. Of this, \$60 was handed over to Vince to pay for the food basket. If you are reading this and did not pay your renewal dues, you need to give a cash, check, or money order to Carl, Sharon, Janet, or Scott as soon as you can. The full amount of \$20.00 entitles you to flying and voting privileges, with \$10.00 for the newsletter only.

As New Business, the club decided to order 24 tee shirts with our round SAM 59 logo on the back, and the SAM crest on the front. Carl Agreed to place the order with the AMA for 12 XXL, 6 XL, and 6 L. Also as new business, we agreed on trying an FAC contest in March, a Harbor Freight event in April, Classic Wakefield in May, combined Scale and Vince Burton Challenge in June, and again having the Gulf States 2-day event in late August or September. See the attached calender for some possible dates.

MY KINGDOM FOR A PROP –From the Nov/Dec 2006 SAM Speaks

The prop diameter of the Gollywock, Jabberwock, and Dyna-Moe have been a constant source of discussion between those enlightened souls who cite plans, articles, and personal conversations with Wally Simmers. Bob Larsh had written a letter to Wally before his death. Wally answered back on the same letter. The letter was found by Thom Greenhaldge, in Jim Adams' archives, after Jim's death. The scanned copy isn't that good, but legible. To put this to bed, here is a transcript of the letter and Wally's response:

Dear Wally,

I've recently heard that you used a 13 1/2 inch diameter prop on your original Gollywock and that the kit was changed to a 12 inch because of the size limitation of the new wood to cut the prop blanks. You also indicated the model flew much better with the larger prop.

If this is true, would you mind sending me a simple signed statement to this effect? As I am on the SAM design Approval Board I may be able to petition the Board members to allow your original size prop to be used in SAM contests, thereby allowing your design to be even more competitive.

Also, please indicate if this is the same case with the Jabberwock and the Dyna-Moe and what original prop diameters were.

Your Friend,

Bob

The answer written on the letter by Wally is:

It is true that I used props of 12-13-13 1/3 on all three models: the Gollywock, Jabberwock, and Dyna-Moe. The limitation of 12" in the kit was because it was the maximum possible to cut on the prop machine.

Thanks for your interest.

Wally Simmers

Now maybe it is put to rest

SAM 59 MEETING SCHEDULE FOR 2007

Friday, Jan 5	J. Damare, M. Hobbies	Saturday, July 7	Tchefuncte Park Picnic
Friday, Feb 2	Open	Friday, Aug. 3	Open
Friday, Mar 2	Open	Friday, Sept. 7	Jim Bethea
Saturday, Apr 7	Picnic, Doug Petty	Friday, Oct. 5	Open
Saturday, May 5	Bakay's in Lafayette	Friday, Nov. 2	Open
Friday, June 1	Open	Saturday, Dec. 8	Scott & Dona Xmas Party

We still have 6 open dates, so please think about hosting a meeting if you haven't already signed up. Call Janet at 985-892-7204 if you can help.

2006 CONTEST & EVENT CALENDAR

- January 27 The Pensacola Free Flight Team is having its first meeting of the year at 12:00 noon on Saturday, January 27, at the Fire Mountain Buffet on Florida Highway 29 North of I-10. Lunch is 12:00 to 1:00 pm, with the meeting afterwards. You do not need to have lunch to attend. There is a show-and-tell, so bring your latest project. Take Florida Interstate 10 to Exit 10, go 1.5 miles north towards Cantonment. A few yards past the Wal-Mart sign is an Office Depot sign. Turn here, and Fire Mountain is right next to Office Depot.
- February 10,11 The Model Airplane Club of Huntsville hosts the **Mach Winter Coupe** Event at the Pensacola Navy Field, Site 8A. See flyer in this issue for entry details. CD: Bob Thoren, 10002 Bluff Drive, Huntsville, AL 35803-1704, phone 256-880-8099. dthoren3@comcast.net
- March 10 **SAM 59 Club FAC Contest for Dime Scale, WWI & WWII Mass Launch.** Simpson Sod Farm, 8 am til 4 pm. Date Approx. CD TBA.
- April 7,8 **SAM 59 Club Harbor Freight Electric, SAM Two-Bit Rubber** Contest. Simpson Sod Farm, 8 am til 4 pm. Date subject to change. CD Carl Bakay 800-676-7302, carl.bakay@scientificdrilling.com
- May 6 **SAM 59 Classic Wakefield Event**, 4 oz and 8 oz combined. Simpson Sod Farm. CD Jim Bethea.
- May 19,20 Model Airplane Club of Huntsville hosts the **Heart of Dixie** National Cup Contest, Navy Site 8A, Pensacola, FL. AMA Gas, Classic Power, OT Rubber, Commercial Rubber, Moffett, F1H Glider, F1D Coupe, Gollywocks Galore, and more. Tom Hepler CD, 256-350-9263. BuzzardBombshell @aol.com
- May 29-Jn 3 **AMA FF Nationals**, AMA Flying Site, Muncie, IN. For info www.modelaircraft.org/events
- June 10 **SAM 59 AMA/FAC Scale, Vince Burton Challenge.** Date approximate, CD TBA.
- June 16,17 Pensacola FF Team hosts the McLaughlin SE Model Airplane Championship, The **Fiesta of Five Flags** Contest. Featuring AMA, SAM and FAI events. Bob Junk CD, 984 Williams Ditch Rd., Cantonment, FL, 32533. Phone 850-968-9619.
- July 7,8 **Dixie Nationals**, sponsored by the Florida Modelers Association, Plam Bay Florida, AMA, FAI, SAM and NFFS Nostalgia events. Saturday 7 am til 4 pm, Sunday 7 am til Noon. CD will probably be Joe Clawson, 321-984-8718, claws3132@earthlink.net.
- Sept 15, 16 The Clouddclimbers of SAM 59 host the **Gulf States Annual**. At Pensacola Navy Site 8A.
3 SAM events - Small stick / Small cabin, Large stick / large cabin, Commercial rubber
3 FAC events – To be announced
3 AMA events– Coupe de’Hiver, P-30.
\$15 entry flies any or all events. CD Carl Bakay.
- Oct 7-12 **SAM Champs 2007**, Eldorado Dry Lake, Henderson, NV. SAM has reserved for \$51/nite Sunday-Thursday, \$89 Fri and Saturday the Fiesta Henderson Station Casino-Hotel, 777 W. Lake Meade Dr., Henderson, NV 89015, Phone: 800-388-8334. Gene Wallock CD, 580-536-0303, velinak@aol.com. Rubber model will be the 50” Greenberg design Miss World’s Fair. Gas model is the 72” Trenton Terror by DeAngelis. Entry Forms send SASE to Registrar George Walter, 2412 Deerpark Dr., Fullerton, CA 92835
- October 6,7,8 **PFFT Gathering of the Turkeys**, Navy Site 8A, Pensacola, FL. CD to be announced.
- Dec 29,30,31 FMA hosts the **King Orange International**, Palm Bay Florida. CD TBA.

Any corrections, additions, please notify Carl Bakay. My contact info is on the masthead on Page 1. Thanks!

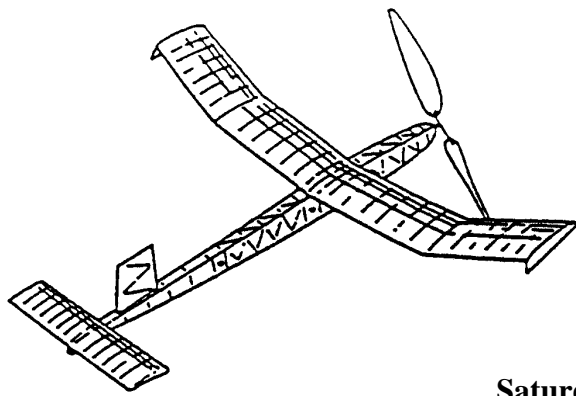

MODEL AIRPLANE CLUB OF HUNTSVILLE, ALABAMA MACH WINTERCOUPE EVENT

Sanction Class A # 07-0039

Pensacola, Florida Navy Helicopter Field Site 8A

Saturday, February 10 and Sunday February 11, 2007

Directions to Site: Take I10 West from Pensacola. Take Exit 5 to Alt 90 and continue west approximately 2 miles to the field

Enter the 18th annual MACH Wintercoupe Event to be held in Pensacola, Florida at Navy Site 8A. **We have the facility for two days.** The glider events (HLG, CLG and Classic Towline Glider) will be flown on Saturday. Coupe d'Hiver will be flown in rounds on Sunday. Sunday's events will also include P-30 and Commercial Rubber. Contest start-stop times are 0800-1600 both days.

This is a National Cup event for HLG,CLG,TLG and P-30
\$10 Entry Fee. Fly any or all events. Plaques to third place

Saturday Events:

ENTRY FORM

- Hand Launch Glider
- Catapult Launch Glider
- Classic Towline Glider — Any glider 750 sq inches max total area projected; No weight requirements; BOM applies; No circle tow; fixed surfaces except for glide rudder; zoom launch OK; No tow time limit

Sunday Events:

- Coupe d'Hiver — 70 gm airframe; 10gm rubber; 5 rounds, 2 minute max
Rounds: 0900-1000, 1000-1100, 1100-1200, (Lunch), 1300-1400, 1400-1500+ Flyoffs until 1600
- P-30 Rubber — 40 gm airframe; 10 gm rubber; 3 flights, 2 minute max
- Commercial Rubber — 36" max wing, freewheel prop; 3 flights, 2 minute max

Signature _____

Name _____ AMA #. _____

Address _____

CD — Bob Thoren, 10002 Bluff Drive, Huntsville, AL 35803, Tel 256-880-8099 email dthoren3@comcast.net
or bob.thoren@tdytsi.com

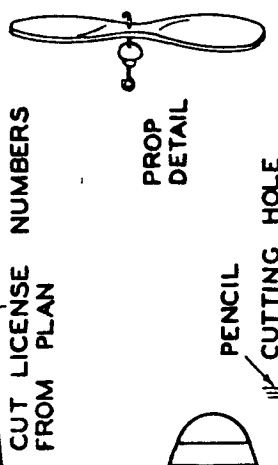
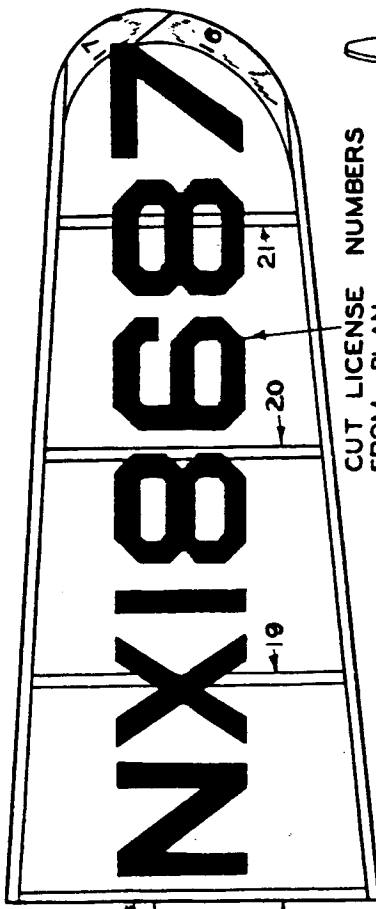
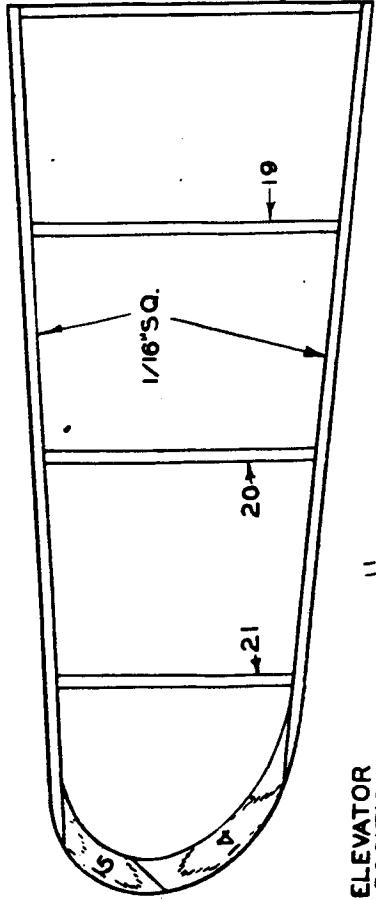

TOP VIEW

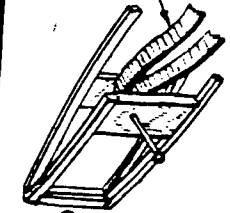
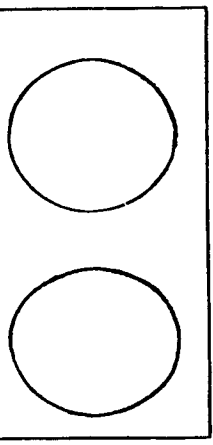
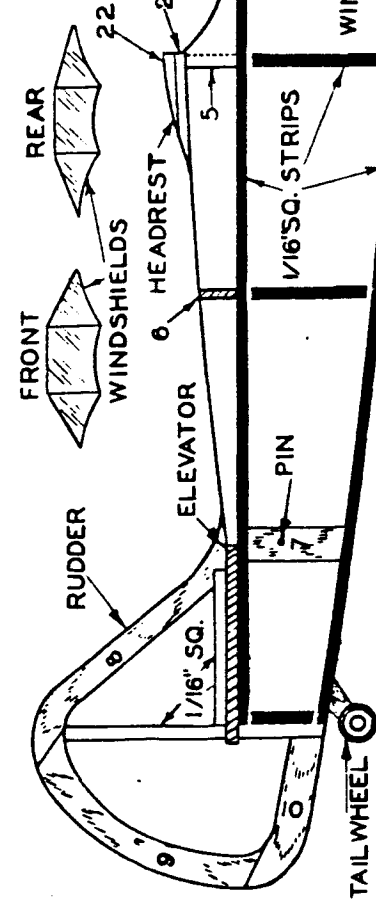
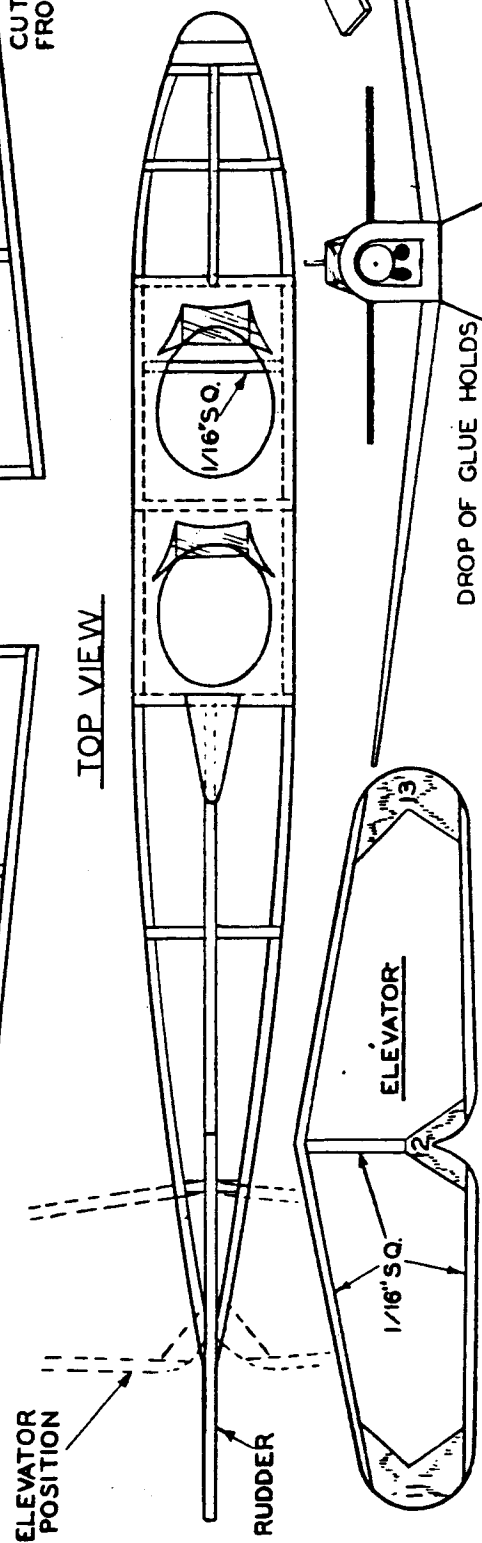

SIDE VIEW

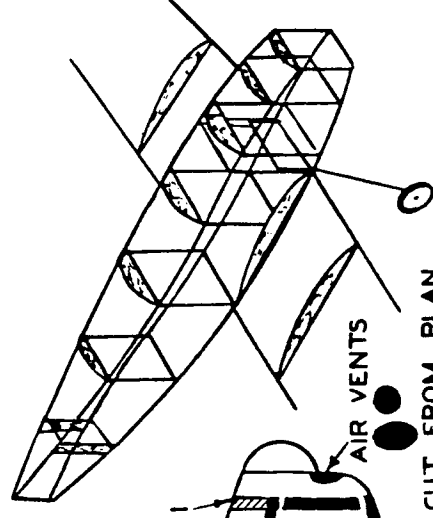

FAIRCHILD

WING SPAN 10" LENGTH 7-3/4"
DRAWN BY *P. Dress* KIT NO. W 8

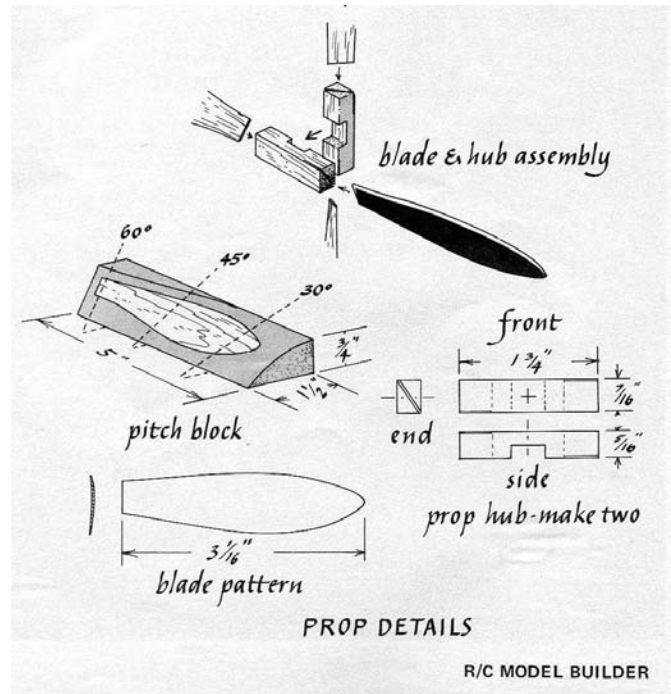

Here is a how-to for making four-bladed props from the November 1979 issue of Model Builder

Carl J. Bakay, Editor
118 Gentry Circle,
Lafayette, LA 70508

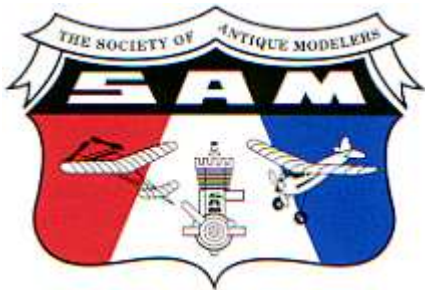
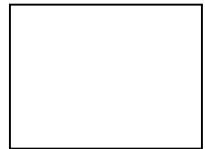

S.A.M. CHAPTER 59

**FLYING
ACES** Club

**GULFHAWKS
SQUADRON #68**

First Class Mail

To: