

WHAM

NEWS VIEWS AND REVIEWS



Official Publication of the Wichita Historical Aircraft Modelers, SAM 56,
and the Kansas Sunflower Squadron, FAC Squadron #23

Issue JE-73
Date: 3/07/08

Prez Says!!

Hi Folks,

It might be hard to believe, but spring is just around the corner. I hope your winter building projects are on the home stretch now so you'll be ready to take full advantage of the warm weather when it finally gets here.

For our next meeting, we're going back to Cortez Mexican Restaurant and I'm thinking about alternating our meetings between there and the Italian Garden for the rest of the year. Let me know what you think of this idea. And also let me of any other places that you think might be a good spot to hold our meetings.

You'll find the minutes of the January meeting in this newsletter, but I'd like to expand a little bit on one item. At the meeting we discussed changing the number of club members necessary to form a quorum. This will require a change to Article V of our constitution which currently says: "A quorum will consist of 50% of the membership or a minimum of ten members, whichever is smaller, and shall be required to conduct business at a regular scheduled meeting."

To change the constitution requires a two-thirds vote of a quorum after the amendment as been read at the previous meeting. So at our next meeting we are going the read the proposed change which will state: "A quorum will consist of 50% of the

Inside this issue:	pg
Meeting Minutes	2
Ideas	3
WHAM Flying Schedule	4
Featured Plan	5
Upcoming Events	6

membership or a minimum of five members, whichever is smaller, and shall be required to conduct business at a regular scheduled meeting." We will then vote on this proposal during our meeting in May.

I look forward to seeing all of you at Cortez on the 15th!

Ed Ross

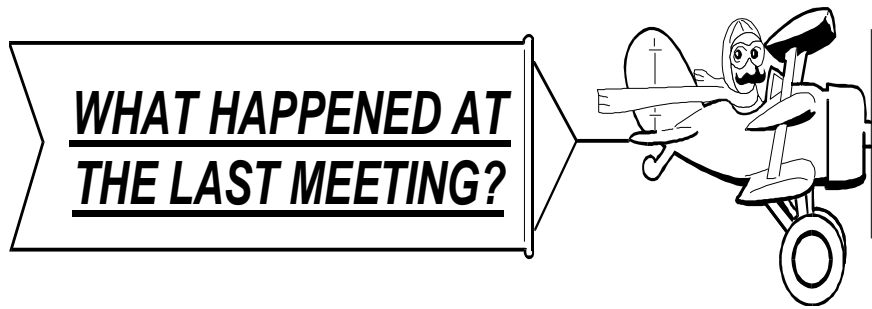

January 26, 2008 Meeting Minutes

ATTENDEES:

Mary Kay & George Avila, Betty & Larry Bishop, Jeff Englert, Jane & Earl Griffith, Marty & Jim O'Reilly, Eleanor & Jack Phelps, Mary Beth & Ed Ross, Ed Salguero, Marilyn & Wilfred Leo Schmidt Jr., Mary Schrock, Dan Walton.

President Ed Ross called the meeting to order.

The previous meeting minutes were approved as published.

Jim O'Reilly presented the treasurer's report.

OLD BUSINESS:

The three year term of officers was reviewed. This motion will be voted on at the next meeting.

NEW BUSINESS:

The schedule for this years activities was approved as published.

It was proposed that the minimum number of club members to form a quorum be reduced from ten to five. This will require a change to the constitution which will be read aloud at the next meeting and voted on at the meeting after that.

A report on this year's Eloy, Az contest was given.

SHOW AND TELL:

Earl Griffith presented a 1/4A Strato-Streak for OT replica events and a 1/4A T-Bird for NOS events. The 0.020 ships were covered in red, white and blue tissue.

Wilfred Leo Schmidt Jr had a 1/4A Strato-Spear and a 1/4A Aero Champ for OT replica events. These were covered in fuchsia silk and white light polyspan. The Cox TEE WEE engines were .020 Tee Dees fitted with Pee Wee metal fuel tanks with 4 point metal backplates. He also displayed a 1938 Atwood Phantom 0.27 ignition engine nicely restored in the original black wrinkle enamel finish.

Dan Walton displayed an Air Hog Aero Ace to show how it is disassembled for 'kit bashing' purposes. The contemporary components are used to make other models.

A Pop-off Wing DT for P-30's by Larry Bagalini

The following was a hand out at the recent Orbiteers general meeting. It was drawn up by John Oldenkamp. The identified parts go a long way to showing how the device is made. Not shown is the line from a wing tip to the rear of the fuselage. A fishing swivel must be placed in this line.

1. Bell crank. Make from thin plastic, aluminum, or ply.
2. 1/8" i.d. aluminum tube. Drill 1/32, then file slot for axle.
3. Bell crank axle. # 90 nylon bolt, paper clip, or thin tubing.
4. Viscous Timer. Badger, Flite Tech or FAI Czech, Buddenbohm, etc.
5. Small stainless steel spring. Some ballpoint pen springs work well.
6. Plastic small diameter cocktail straw runs through pylon.
7. Spider wire lanyard. From WalMart fishing department or 10# monofilament.
8. .020 or .015 inch closed loop music wire turnaround.
9. Wing held down with 2 #10 bands tied together.
10. .5 or .75 oz. glass clothe over turnaround. Attach with CyA glue.

(Larry ties the bands to the peg at illustration 9 to keep from losing the bands.)

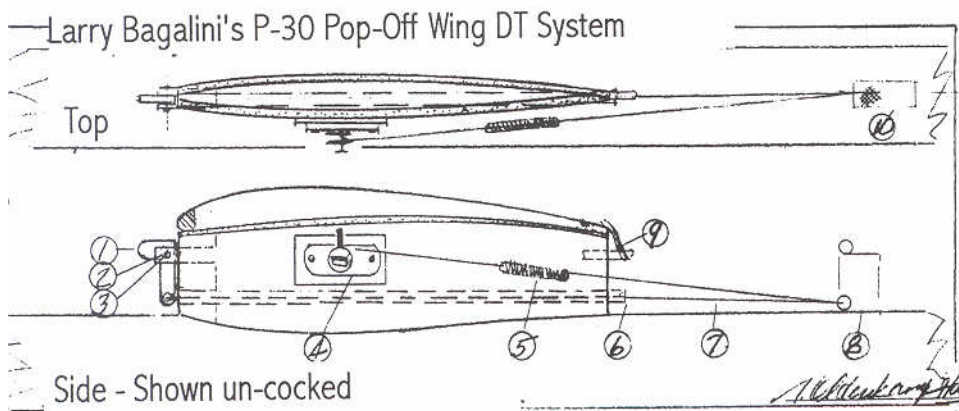

A Walston Retrieval System is FOR SALE by Jack Phelps for \$500.00.

Call Jack at (316)838-8144 or E-mail at jackp5149@juno.com .

Walston Retrieval System complete with the following:

Receiver model TRX-3S SN 3961896 Operating on 3 channels as follows

- A 220.010 – 220.020 frequency range
- B 220.050 – 220.060 frequency range
- C 220.090 - 220.100 frequency range

The receiver uses 8 AAA Alkaline batteries. Batteries included

Transmitter (airborne unit) MODA 2338 On Channel C at 220.095mhz

Uses 3 Energizer 392 batteries. Batteries included

Antenna , Folding, Model F220-3FBSN 07084, with coax cable and original case and strap.

The above items for sale NEW can be viewed at the website below.

<http://www.walstonretrieval.com/main.htm>

WHAM 2008

FLYING SCHEDULE

- Apr 5, Kansas Science Olympiad State Championship
- April 12-13, fly SAM 1/2A Texaco R/C, NFFS 1/2A NOS FF, FAC Moth, FAC Dime Scale
- May 17-18, Meeting, fly FAC Jimmy Allen, SAM LER R/C, FAC Old Time Rubber, SAM Catapult Glider
- Jun 7-8, fly SAM 1/2A Texaco R/C, FAC and SAM Small Rubber Combined, NFFS 1/4A NOS, FAC/SAM Old Time Gas Replica
- July 19-20, Meeting, fly SAM 1/2A Scale R/C, FAC Golden Age Civil Scale, FAC WWII Mass Launch, FAC/SAM .020 Replica
- August 9-10, fly FAC Old Time Gas Replica, SAM LER R/C, FAC and SAM Small Rubber Combined, WHAM Post 1940 Civilian
- September 13-14, Meeting, fly SAM 1/2A Texaco R/C, SAM 1/2A Scale, SAM LER R/C, WHAM Rubber Scale (30" Max Span), SAM Small Rubber Stick, SAM Small Rubber Fuselage, SAM OT HLG, SAM Catapult Glider, FAC/SAM .020 Replica
- October 18-19, fly FAC Moth, FAC Golden Age Civil Scale, FAC Old Time Rubber, FAC Embryo, FAC/SAM Old Time Gas Replica, FAC Golden Age (Civil or Military) Scale Mass Launch, FAC Greve & Thompson Mass Launch, FAC WWII Mass Launch, FAC WWI Mass Launch
- November 8-9, Meeting, Outdoor Fun Fly

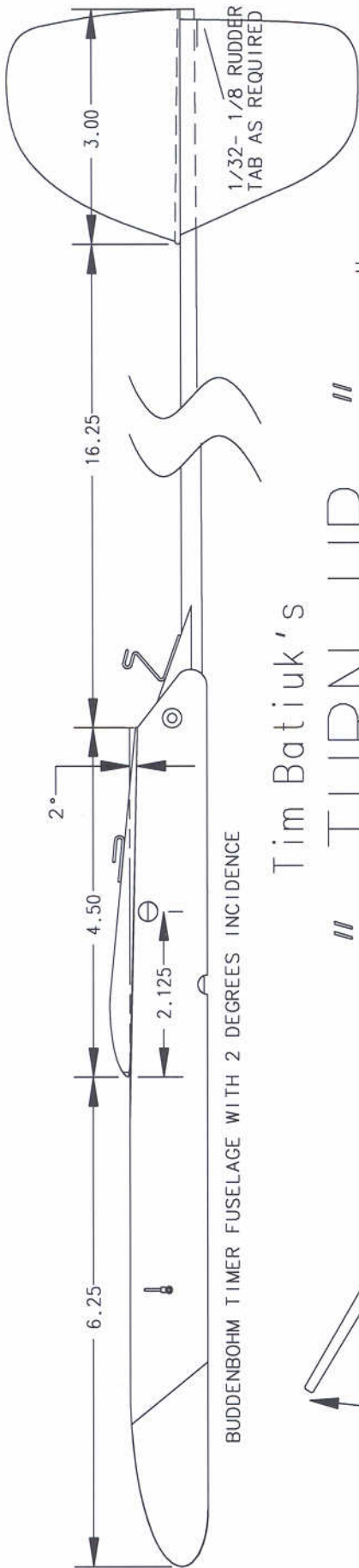

Tim Batiuk's TURN-UP

NATIONAL RECORD HOLDER 43:51 10/06/07

36" SPAN TLG FLIES LEFT-RIGHT
TARGET WEIGHT 85 GRAMS
1ST PLACE 2007 FREE FLIGHT CHAMPS
1ST PLACE 2007 NATIONALS
2 CONTEST WINS WITH 11 MAXES EACH

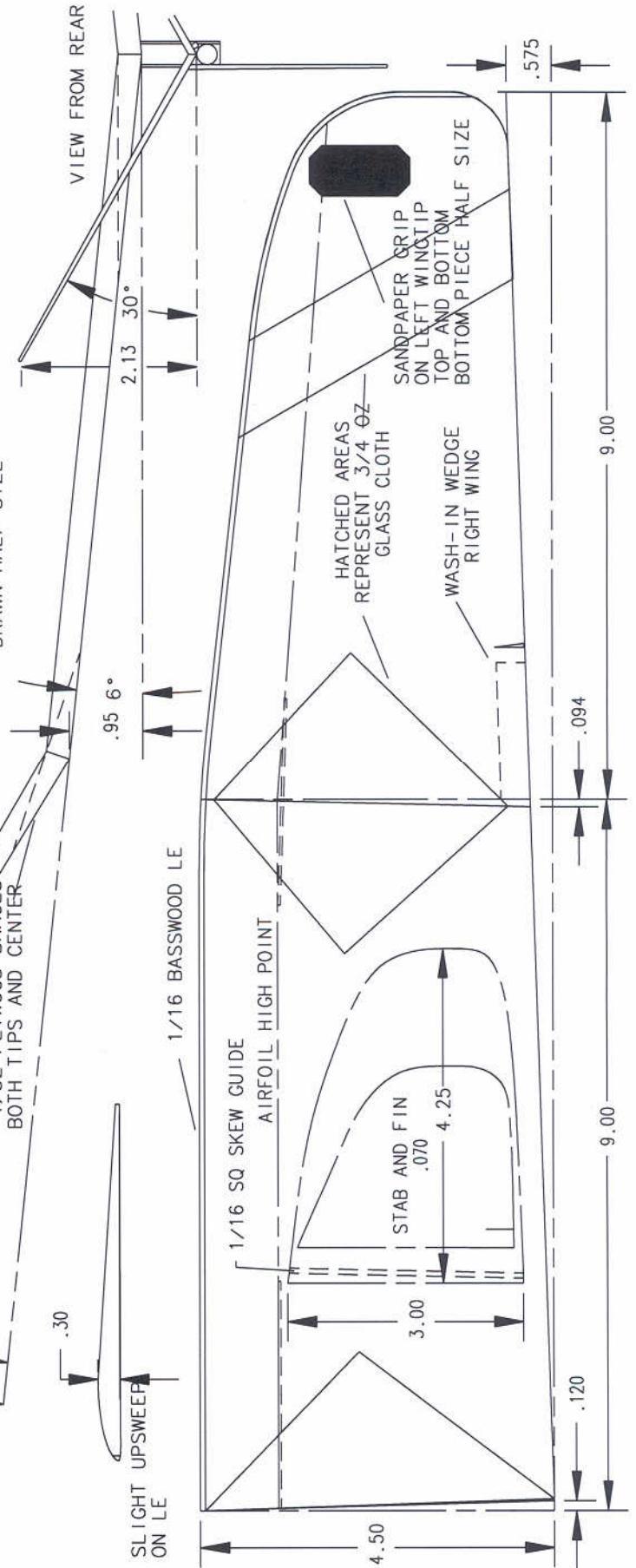
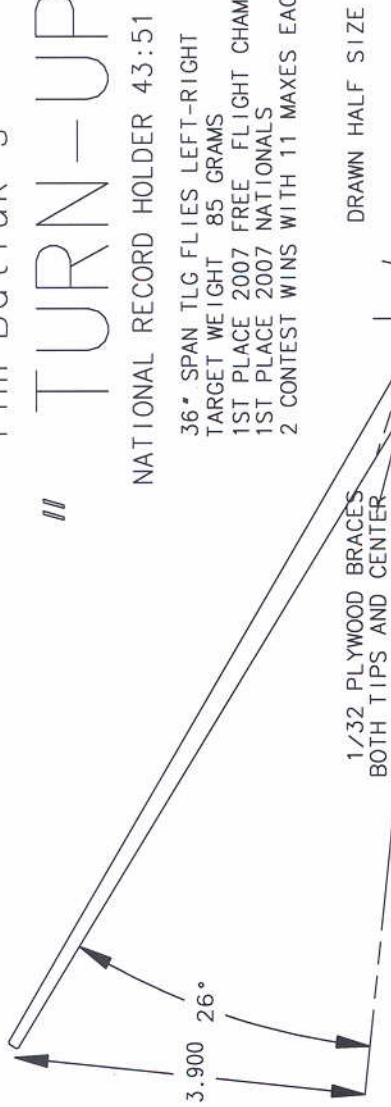
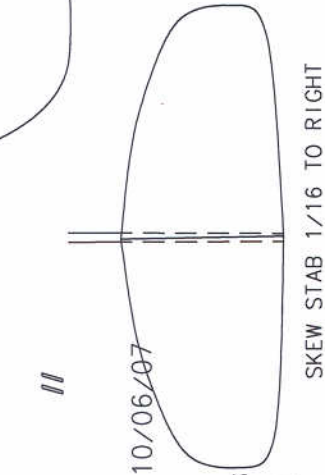

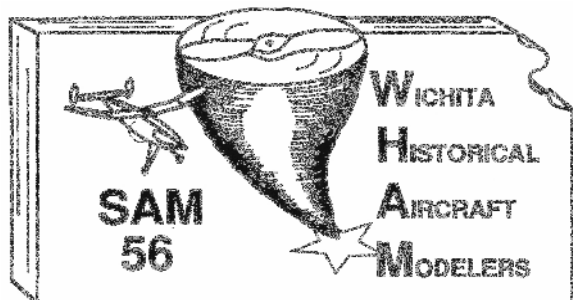

FLYING ACES

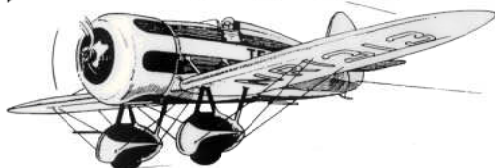

**Sunflower Squadron
Wichita, KS**

Date: 3/07/08 ISSUE JE-73

→ The next SAM 56 Dinner Meeting will be at:

**Cortez Mexican Restaurant
344 W. 29th St.**

Saturday, March 15, 2008
Social Hour @ 6:00 PM, Dinner @ 7:00 PM.

Upcoming Events:

→ **Membership Information:**

Open to all interested AMA members, founded to encourage and promote the model airplane building hobby.
Member dues \$20 annually, Subscription only; \$12 annually, \$18 foreign.
Send checks to Jim O'Reilly, 4760 Battin, Wichita, KS 67220.
All memberships and subscription renewals are due January 1st of the new year.

<u>Club Officers:</u>	President:	Ed Ross, 682-9692	Vice-President:	Bill Lindsay, 689-8491
	Treasurer:	Jim O'Reilly, 744-0856	Secretary:	Bill Schmidt, 744-0378

ATTENTION: The new year requires you (unless your address label says different) to submit a monetary

renumeration to continue membership in the club and to receive this newsletter (if mailed). To those that are on the email distribution, a monetary contribution is always welcomed. Note even though the inflationary trends of the world continue, (printing cost increases, etc.), the amount of our yearly dues didn't increase (**STILL \$20**). Please send your dues or subscription fee (**STILL \$12**) to our club treasurer. Please consider a multiple year renewal, its cheap!