

# WHAM



Issue JE-106  
November 2, 2013

Official Publication of the Wichita Historical Aircraft Modelers, SAM 56,  
and the Kansas Sunflower Squadron, FAC Squadron #23

## NEWS, VIEWS and REVIEWS

### Earl's Rubber Stretching Investigation

This July while in Muncie practicing for the NATS Joe Williams noticed that I wasn't stretching my rubber motors as much as is often recommended. Joe commented that I was giving away turns and torque. Really, I had better look into this. Stretching rubber to seven times its relaxed state is an amount I have seen recommended although I cannot site a source. Also, although I have heard this recommendation and seen it practiced by other modelers I have never seen any data on the practice. So, I set up the following test. I made up ten motors of six strands of 1/8<sup>th</sup> inch rubber six inches in length. The motors were washed and lubed and of course came from the same batch of FAI rubber. Five motors were stretched 2 times the relaxed length and immediately wound with turns to about one half of maximum torque, then I would start moving in until the motor broke. Torque recorded by research assistant, Jane. The second set of five motors were stretched 7 times the relaxed length and wound the same as the previous set.

This is the results of those tests.

Rubber stretched 2X			Rubber stretched 7X		
Motor	Turns	Torque	Motor	Turns	Torque
#1	316	12	#1	368	17.5
#2	332	12	#2	352	16
#3	336	14	#3	356	19.5
#4	320	11	#4	360	16
#5	340	14	#5	364	20
Average	328.8	12.6	Average	360	17.8

Well wouldn't you know it, Joe was right on both accounts. The results show turns increased by about 9.5% and torque by about 41%. Jeepers. Although, these test are limited by small number, only five motors in each group, there is no overlap between the two. The highest torque in the 2X group (14) is less than the lowest torque (16) in the 7X group. This is good to know.

Now You Know!  
Earl Griffith

**September 14, 2013 Meeting Minutes****ATTENDEES:**

Mary Kay & George Avila, Lori & Phil Burris, Paula & Jeff Englert, Jane & Earl Griffith, Regina & Marty Kline, Darlene & Richard Kirkland, Marty & Jim O'Reilly, Eleanor Phelps, Chuck Powell, Ed Salguero,

President Avila called the meeting to order.  
The previous meeting minutes were approved.  
The treasurer's report was presented by Jim O'Reilly.

**OLD BUSINESS:**

George reported the south end of the field has been mowed but not baled.

Reports from participants at the Denver and Perry contests reported. Reminder on the Upcoming Marion Contest was presented.

**NEW BUSINESS:**

The treasurer reported on having to change banks due to service charges. The president reminded everyone that elections will be held at the next meeting.

Ed S. moved that the club executive committee met to audit the club expenses to assure that the club status would not be impacted by IRS rules. Motion seconded and passed.

Ed. S. moved that the executive committee review club direction/target for the future. Motion seconded, but tabled to next meeting.

**SHOW AND TELL:**

Earl Griffith showed the Mulvihill traveling trophy from the MMM Denver Contest. Very pretty and impressive.

Marty Kline displayed a MID-MAT catapult glider design version of the Tony Matthews design with Stan Buddenbohm inspired features.

## Meeting Minutes (Continued)

**SHOW and Tell**

Phil Burris displayed his Flying Aces Moth, built from Bill Schmidt's redrawn plans. (He would go forward and take Small Fild Combo at the Sept Perry Contest). He also had a 1/2 Awake built from the easy built kit.

Jim O'Reilly brought in a Don Burnam Twin Pusher and his dual rubber winder used to prepare it for flight.

Richard Kirkland detailed the stomp rocket build features, both for the rocket and power section.



Bill Schmidt's Vought SB2U-2 Vindicator from  
Pres Burning plans

GRN

REFERENCE DATA

OCT 77 ISSUE OF SPORT FLYING MAGAZINE FOR PHOTOS AND COLOR PROOF. STD. COUGAR 3 VIEWS FROM JUL 76 MODEL AVIATION PAGE 31.

ENTIRE AIRFRAME COVERED WITH MICRO-X OLD WORLD ORANGE TISSUE, ALCOHOL SHRUNK. MASK WINDOWS & AIRBRUSH | LIGHT COAT OF AEROGLOSS 52-1 CUB ORANGE DOPE WELL LACED WITH T.C.P. AIRBRUSH STRIPES & NUMBERS WITH FLOQUIL R36 WEYER. GREEN. OUTLINE ALL WITH WHITE INK FROM RAPIDOGRAPH PEN.

PROTOTYPE WEIGHT: 11 GMS.

POWER: .125 x .043 x 26" LOOP FA1 BROWN 1500 TURNS.

This free plan courtesy of the Rees Family

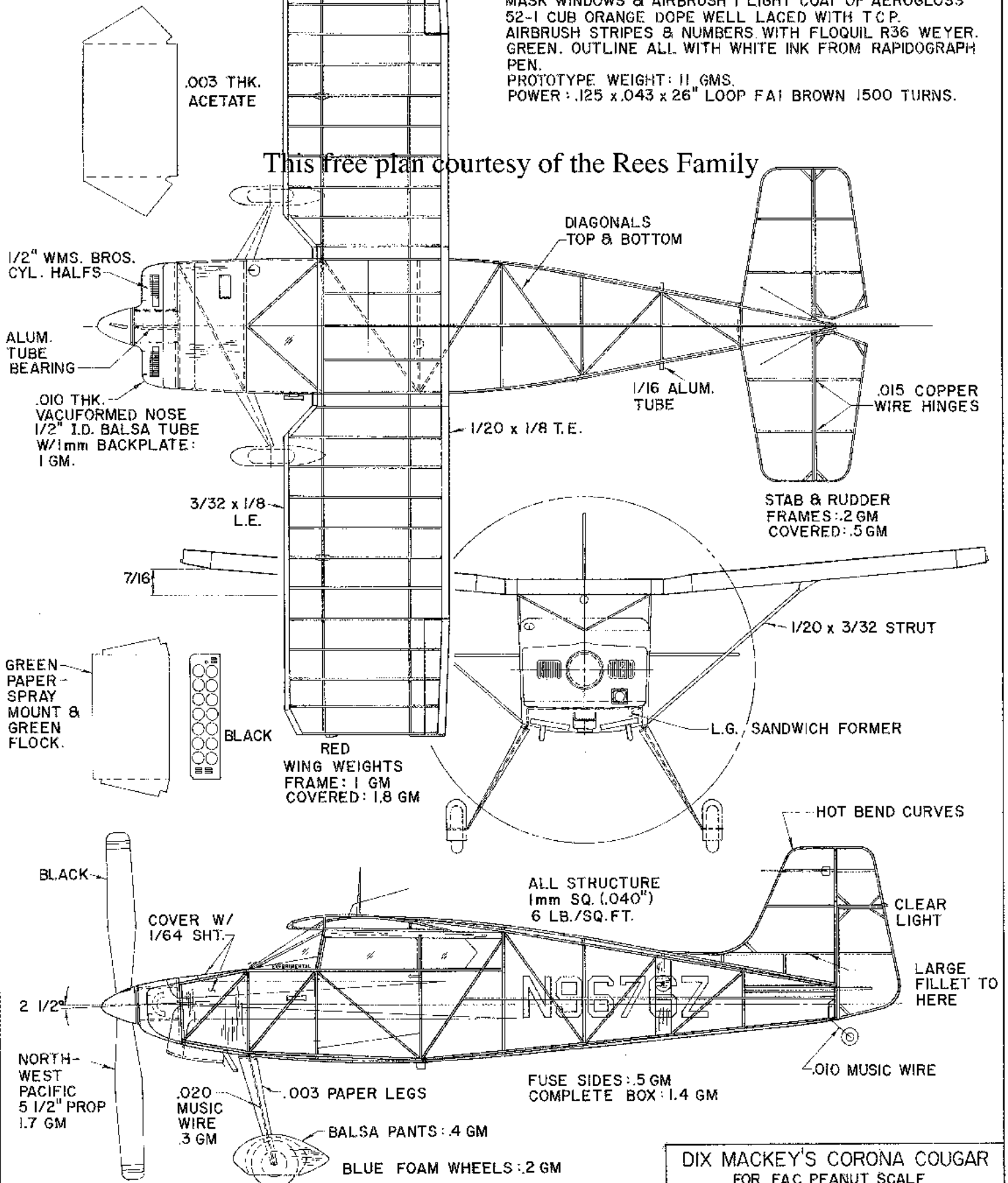

.003 THK. ACETATE

1/2" WMS. BROS. CYL. HALFS

ALUM. TUBE BEARING

.010 THK. VACUFORMED NOSE 1/2" I.D. Balsa TUBE W/1mm BACKPLATE: 1 GM.

3/32 x 1/8 L.E.

7/16

GREEN PAPER SPRAY MOUNT & GREEN FLOCK.

BLACK

RED WING WEIGHTS FRAME: 1 GM COVERED: 1.8 GM

BLACK

COVER W/ 1/64 SHT.

2 1/2"

NORTH-WEST PACIFIC 5 1/2" PROP 1.7 GM

.020 MUSIC WIRE 3 GM

.003 PAPER LEGS

BALSA PANTS: 4 GM

BLUE FOAM WHEELS: 2 GM

DIAGONALS TOP & BOTTOM

1/16 ALUM. TUBE

1/20 x 1/8 T.E.

.015 COPPER WIRE HINGES

STAB & RUDDER FRAMES: 2 GM COVERED: 5 GM

1/20 x 3/32 STRUT

L.G. SANDWICH FORMER

HOT BEND CURVES

ALL STRUCTURE 1mm SQ. (.040") 6 LB./SQ.FT.

CLEAR LIGHT

LARGE FILLET TO HERE

.010 MUSIC WIRE

FUSE SIDES: 5 GM COMPLETE BOX: 1.4 GM

DIX MACKEY'S CORONA COUGAR FOR FAC PEANUT SCALE BY WALT EGGERT AND DAVE REES 1992



WHAM – News, Views and Reviews  
Jeff Englert  
10118 Sterling Court  
Wichita, KS 67205

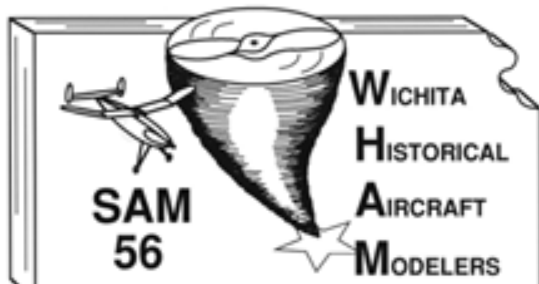

**FLYING  
ACES**



**Sunflower Squadron  
Wichita, KS**

The next SAM 56 Dinner Meeting will be at:

**Mediterranean Grill**

**335 S Towne East Mall Dr., Wichita, KS 67207**

**(316) 651-5599**

**Saturday, November 9, 2013**

**Social Hour @ 6:00 PM, Dinner @ 7:00 PM..**

**Upcoming events:**

**November 9 – 10, The 2013 1/2A Texaco Finale – GO FOR the Trophy & Fun Fly**  
General fun fly, bring out what ever has survived the year, fly for fun.

**Membership Information:**

Open to all interested AMA members, founded to encourage and promote the model airplane building hobby. Member dues \$20 annually, Subscription only; \$12 annually, \$18 foreign.

Send checks to Jim O'Reilly, 4760 Battin, Wichita, KS 67220.

All memberships and subscription renewals are due January 1st of the new year.

Club Officers: President: George Avila, 683-1474 Vice-President: Bill Schmidt 744-0378,  
Treasurer: Jim O'Reilly, 744-0856 Secretary: Jeff Englert, 722-7491