

# WHAM

## NEWS, VIEWS and REVIEWS

Issue JE-90  
March 11, 2011

Official Publication of the Wichita Historical Aircraft Modelers, SAM 56,  
and the Kansas Sunflower Squadron, FAC Squadron #23

### Where to Go Next?

Sitting here trying to assemble enough pictures, plans, words, or whatever to justify calling this a newsletter, gives one cause to wonder if the effort is worth it. It's not that having a club newsletter doesn't serve a purpose. As without some form of club communication, I don't really believe any club would last long. So other than serving as a reminder that the next meeting is approaching, and providing a schedule of other events (possibly even other fairly close activities) - What Other Information is desired?

What makes a newsletter editor's job tough is assembling enough other items that serves to satisfy other member's interests. I know that once I've put an issue together, I have no need for it anymore. So the question is what does everyone else want?

For the most part, there is no particular point behind the subject matter found in the NL. I've usually tried to put in a short article discussing some subject and a plan or two for interest. Obviously, I solicit anything I can, but it doesn't pout in. A number of other NL's have a more structured approach, which seems to serve a purpose. I look forward to receiving MAX-FAX, Alamo Escadrille, New England's Tailspin, Cleveland Crosswind and the Cloudbuster's NLs. They seem to have a usual format. Some cover the a couple of airplane in detail, some utilize a guest editor. Pick up the main FAC NL and unless they are promoting the non-Nats, NATS or the KANONE standings, I sometimes think it wasn't worth the effort.

So anyway, take a few minutes and think about what you want to see every other month. I'd like to get a more specific picture of our needs and wants to better define what needs to be delivered. Take notes, bring them to the next meeting, email me or even just call.

I don't want to quit, I just want to have a better defined target to hit!

Thermals,  
Jeff

## January 22, 2011 Meeting Minutes

### **ATTENDEES:**

Mary Kay and George Avila, Larry Bishop, Les DeWitt, Paula & Jeff Englert, Jane & Earl Griffith, Regina, Marty Kline, Bill Lindsey, Jim O'Reilly, Charleen & Ed Salguero, Eleanor and Jack Phelps, Marilyn and Bill Schmidt, Dan Walton. Billy Foster, Lynn Jost – visiting

President Avila called the meeting to order.

The previous meeting minutes were approved as read.

The treasurer's report was read by the treasurer, Jim O'Reilly

### **OLD BUSINESS:**

1/2A Texaco Perpetual Trophy awarded to Jeff Englert for 2010 scores!.

### **NEW BUSINESS:**

Proposed Schedule approved!

### **SHOW AND TELL:**

Jeff Englert showed off an almost completed 30" span Taylorcraft built from enlarged plans of Bill Schmidt's.

Bill Schmidt displayed his As-OK Custom Design version of an old nostalgia ship pictured in a Model Airplane News advertisement. He also had a 1953 Cessna 180, with a 30" span. Done from his own plans from a old Cessna drawing.

Dan Walton had Vapor ARF to which a old CO2 model wing was installaed and used to win the climb and glide competition a the last indoor.

George Avila gave away old plans!

V-FORM

FINN

1:1

1:1

VINGER OG HALEPLAN  
4,5 MM BALSÅ

MODELLEN KAN LÆGSES I  
ALL-FRÆVE OG RØGNES MED  
DANSKE MÆRKE

KROP 5 MM BALSÅ

BLY



1:1

LILLE BITTE VINKELFORSKEL

FINNE 4,5 MM B.

BRETTNING.

ALLE KANTER ARRUNDDES

1.007/1713135

STARTES MED GOD  
ELASTIK.  
4,5 MM PIANOTRØ

EN MODEL FRA 60' DRIVE  
FUNDET AF KØBLO KRISTIANSEN

NORTH AMERICAN  
F-100 SUPER SABRE

## WHAM 2011 Contest Schedule

Mar 19	Meeting	Site to be determined
Apr 16/17	Contest	Events: 1/2 Tex A, Cat G*
May 21/22	Meeting Cortez,	Contest Events: 1/2 A Nos, FAC Small Rubber
Jun 11/12	Contest	Events: Embryo, FAC WW II & Mass Launch
Jul 16/17	Meeting Site to be determined	Contest Events: 1/2A Tex, P-20**
Aug 13/14	Contest	Events: 1/2A Nos, FAC Moth, Cat G*
Sep 17/18	Meeting Site to be determined,	Contest Events: FAC Golden Age & Mass Launch, 1/2A Tex
Oct Dates Open*	Contest	Events: SAM Small Rubber, Builders Choice***
Nov 13	Meeting Cortez Election for 2012	

\*Cat G Standard Launch Device, 18 ins of 1/4 in rubber or 36 ins of 1/8 in rubber, max span 12ins

\*\*P-20 Small rubber model with any dimension a max of 20 ins, prop builders choice, max of 5 grams of rubber. ( Works out out approximately 4 stands of 1/8th rubber by 15 ins.)

\*\*\*Choice- events to be determined at Mar meeting, limit 2 or 3.

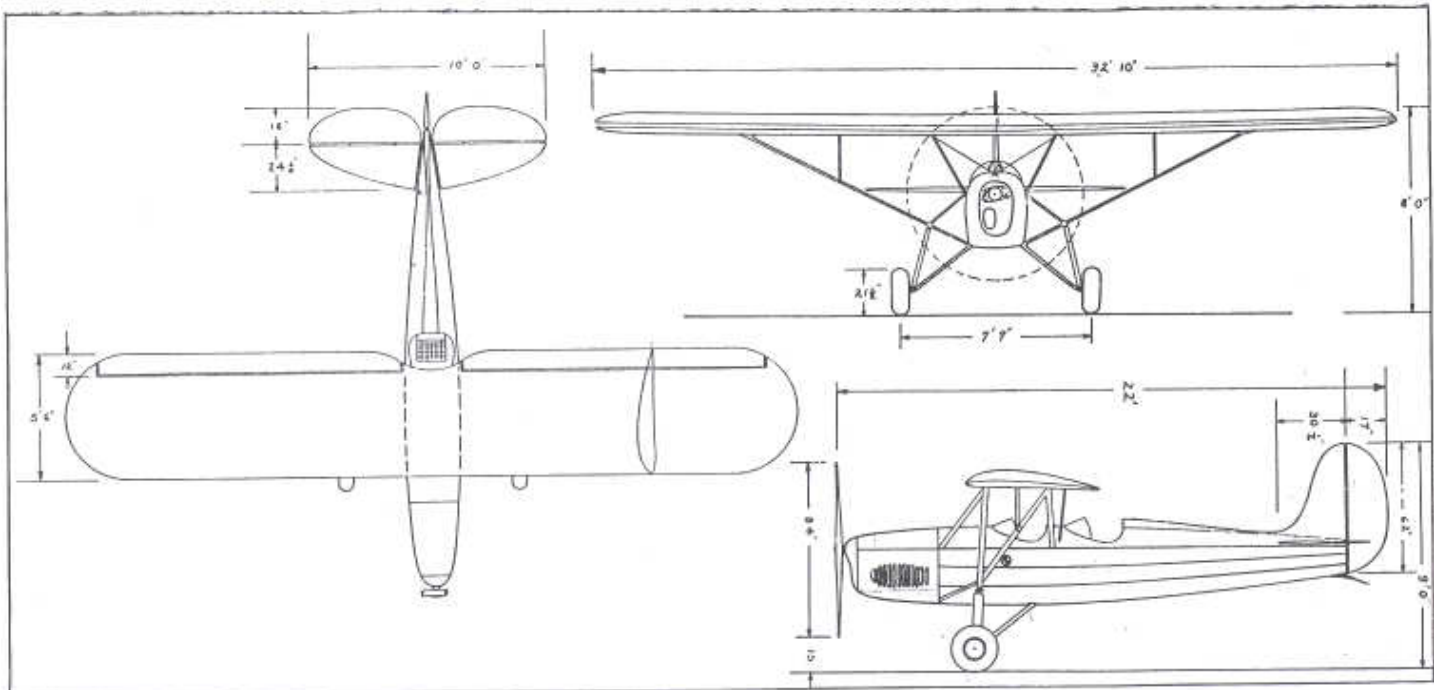



# Le MORANE SAULNIER type H

23 Septembre 1913 première traversée de la Méditerranée en aéroplane par **ROLAND GARROS** qui vole de Saint Raphaël à Bizerte en 7<sup>h</sup> 53

Distance 750 Kms



Documentation: les Aéroplanes 1914-1915 Aviation Suisse... la MIRA Compagnie Elétrique

Appareil reconstruit par Jean Solis

Couleur Toile écarlate

Bleu Jaune et Noir

Coupe vent octaire 2/10

balsa 8/10



Capot astaté 8/10 Vasofarmé Recouvrement balsa 4/10



Position des ailes une boucle de 45° longueur 400 mm pour un poids de cellule de 100g

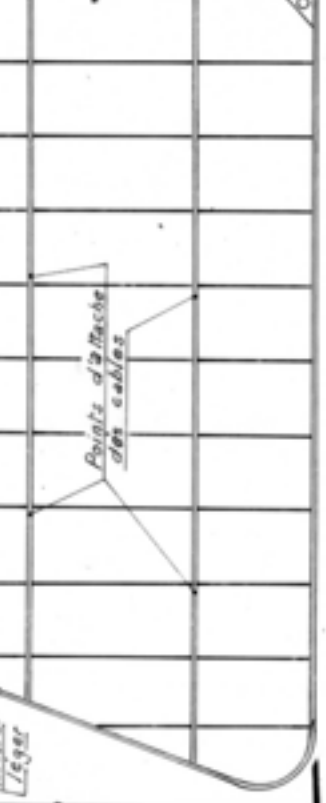

Pointe Bristol Léger

Moquette Volante taille "PEANUT" longueur 230 mm par E. Fillon Aëromodéliste

Recouvrement général papier condensateur 84



Centre de gravité

Bandes de couvrir laiton

Blige

Jaune Bleu Noir

Scale

Entendeur Cap 6/10

Soudé

Cartier et 9

Cylindres Williams 3 B Scale polystyrène formé 1/1

Cap 4/10

Casser en bois les cylindres

Bambou 4/10 Contours à l'échelle

balsa 4/10

balsa 2x1

balsa 1x1

Centre de gravité

Bandes de couvrir laiton

Blige

Jaune Bleu Noir

Scale

Entendeur Cap 6/10

Soudé

Cartier et 9

Cylindres Williams 3 B Scale polystyrène formé 1/1

Cap 4/10

Casser en bois les cylindres

Bambou 4/10 Contours à l'échelle

balsa 4/10

balsa 2x1

balsa 1x1

Colle les ailes recouvertes sur le fuselage terminé décoré diétre ici 40 mm

Colle les ailes recouvertes intrados extrados; Stabils et dérive de même fendu à l'alcool

Pointe d'attache des cables

balsa 4/10

balsa 2x1

balsa 1x1

Centre de gravité

Bandes de couvrir laiton

Blige

Jaune Bleu Noir

Scale

Entendeur Cap 6/10

Soudé

Cartier et 9

Cylindres Williams 3 B Scale polystyrène formé 1/1

Cap 4/10

Casser en bois les cylindres

Bambou 4/10 Contours à l'échelle

balsa 4/10

balsa 2x1

balsa 1x1

Colle les ailes recouvertes sur le fuselage terminé décoré diétre ici 40 mm

Colle les ailes recouvertes intrados extrados; Stabils et dérive de même fendu à l'alcool

Pointe d'attache des cables

balsa 4/10

balsa 2x1

balsa 1x1

Centre de gravité

Bandes de couvrir laiton

Blige

Jaune Bleu Noir

Scale

Entendeur Cap 6/10

Soudé

Cartier et 9

Cylindres Williams 3 B Scale polystyrène formé 1/1

Cap 4/10

Casser en bois les cylindres

Bambou 4/10 Contours à l'échelle

balsa 4/10

balsa 2x1

balsa 1x1

Colle les ailes recouvertes sur le fuselage terminé décoré diétre ici 40 mm

Colle les ailes recouvertes intrados extrados; Stabils et dérive de même fendu à l'alcool

Pointe d'attache des cables

balsa 4/10

balsa 2x1

balsa 1x1

Scale

Recouvrement général papier condensateur 84

Aëromodéliste

Moquette Volante taille "PEANUT" longueur 230 mm par E. Fillon

Centre de gravité

Bandes de couvrir laiton

Blige

Jaune Bleu Noir

Scale

Entendeur Cap 6/10

Soudé

Cartier et 9

Cylindres Williams 3 B Scale polystyrène formé 1/1

Cap 4/10

Casser en bois les cylindres

Bambou 4/10 Contours à l'échelle

balsa 4/10

balsa 2x1

balsa 1x1

Colle les ailes recouvertes sur le fuselage terminé décoré diétre ici 40 mm

Colle les ailes recouvertes intrados extrados; Stabils et dérive de même fendu à l'alcool

Pointe d'attache des cables

balsa 4/10

balsa 2x1

balsa 1x1

Echelle 1/25:122

64

WHAM – News, Views and Reviews  
 Jeff Englert  
 10118 Sterling Court  
 Wichita, KS 67205



FLYING  
ACES



Sunflower Squadron  
 Wichita, KS

The next SAM 56 Dinner Meeting will be at:

**Mediterranean Grill**

**335 S Towne East Mall Dr., Wichita, KS 67207**

**(316) 651-5599**

**Saturday, March 19, 2011**

Social Hour @ 6:00 PM, Dinner @ 7:00 PM.

**Upcoming events:**

Apr 16/17    Contest        Events: 1/2 Tex A, Cat G\*

May 21/22    Meeting Cortez,        Contest Events: 1/2 A Nos, FAC Small Rubber

**Membership Information:**

Open to all interested AMA members, founded to encourage and promote the model airplane building hobby. Member dues \$20 annually, Subscription only; \$12 annually, \$18 foreign.

Send checks to Jim O'Reilly, 4760 Battin, Wichita, KS 67220.

All memberships and subscription renewals are due January 1st of the new year.

Club Officers: President: George Avila,

Vice-President: Bill Schmidt 744-0378,

Treasurer: Jim O'Reilly, 744-0856

Secretary: Jeff Englert, 722-7491